

**RoHS**  
**Compatible**

△				
△				
△				
△				
ZONE	REV	DESCRIPTION	DATE	APPD.

Circuit diagram

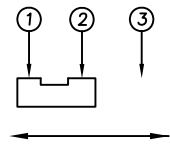

P.C.B Mounting pattern Dimension

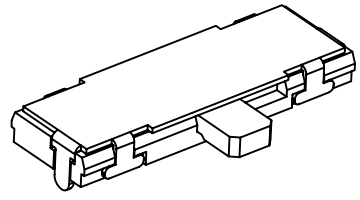
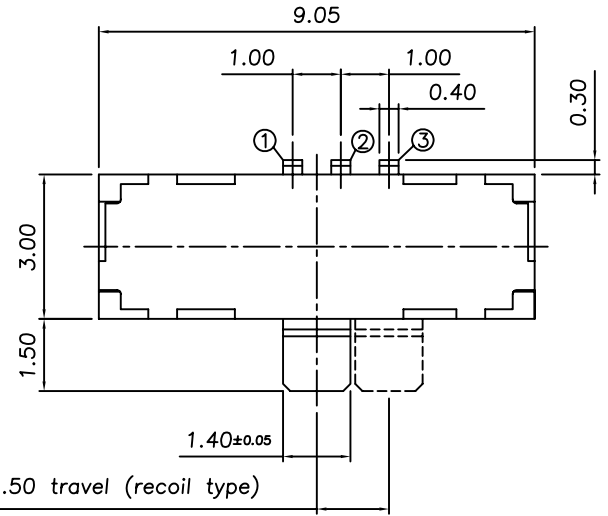
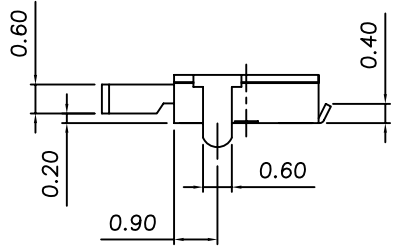
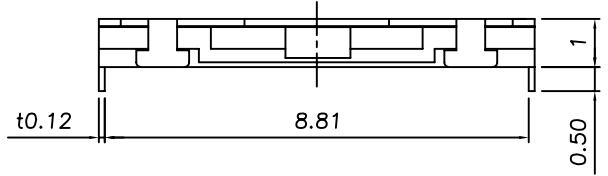
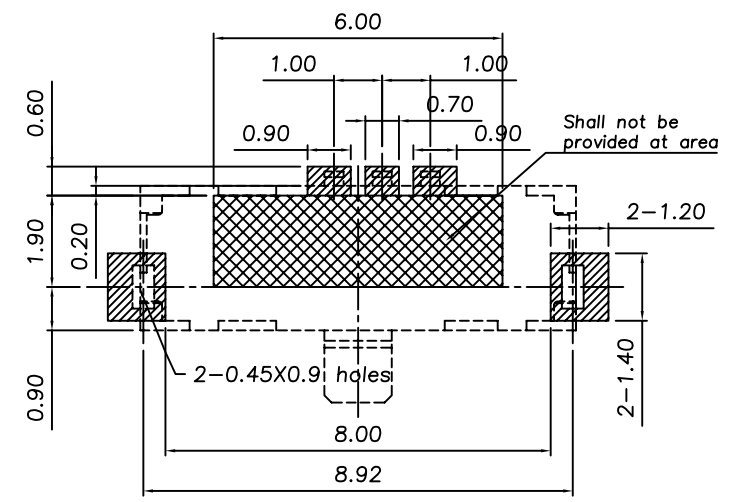

Specification

1. Rating : 10mA, DC 5V Max.
2. Contact resistance : 200mΩ Max.
3. Travel : 1.5±0.3mm
4. Operating force : 100±50gf
5. Operating life : 10,000 cycles Min.

6	Clip	Phosphor Bronze	1	Ag Clad
5	Spring	Stainless Steel	1	
4	Cover	Stainless Steel	1	Ag Plated
3	Knob	PA6T+SUS	1	Black
2	Case	LCP	1	Black
1	Terminal	Phosphor Bronze	1	Ag Plated
No.	Part Name	Material	Q"ty	Finishing

**達立科技股份有限公司**  
**Dawning Precision Co.,Ltd.**  
TEL: 886-2-82271388 FAX: 886-2-82272198

DESIGN	Will	SCALE		
DRAWING	Will	UNIT	mm	
CHECK	Will	SIZE	A4: 210*297	
APPROVAL	Eric	VERSION	01	

TOLERANCE UNLESS OTHERWISE STATED(mm)	PART NAME	SLIDE SWITCH
less than 10 — ±0.3	PART NO	SS-B72-S001
10~30 — ±0.4	DRAWING NO	
30~100 — ±0.5	DATE	2012/08/29
ANGIE — ±2°		