

▲				
▲				
▲				
▲				
ZONE	REV	DESCRIPTION	DATE	APPD.

Circuit diagram

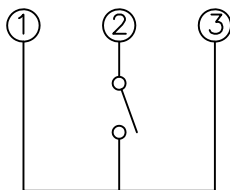

Specification

1. Rating : DC 12V 50mA Max.
2. Contact resistance : 100mΩ Max.
3. Insulation resistance : 100MΩ Min.
4. Travel : 0.15±0.1mm
5. Operating life : 30,000 cycles Min.
6. Operating force: 350±50g

發行
2013.05.27
達立

RoHS
Compatible

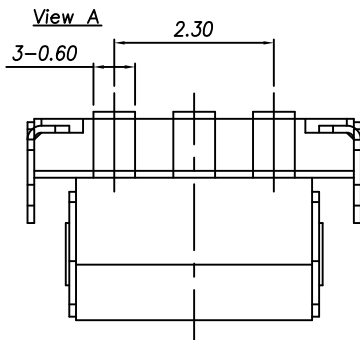
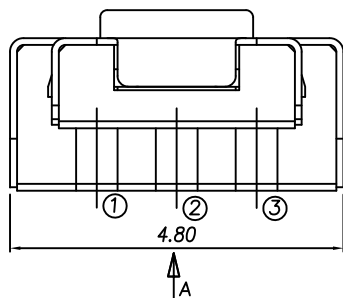
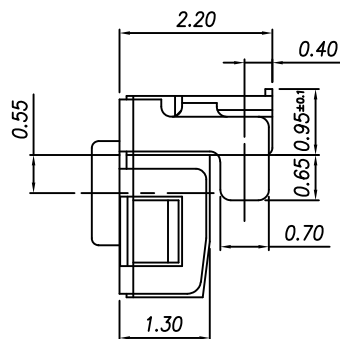
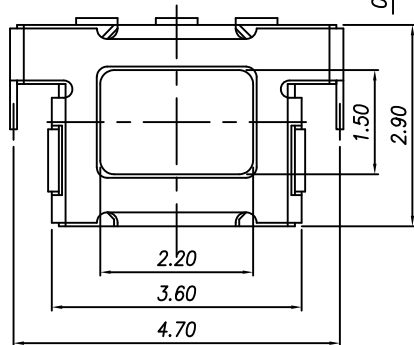
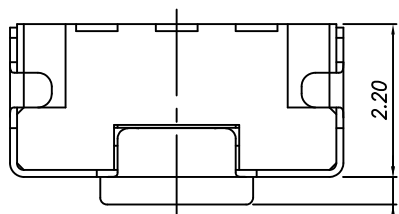

P.C.B Mounting pattern Dimension

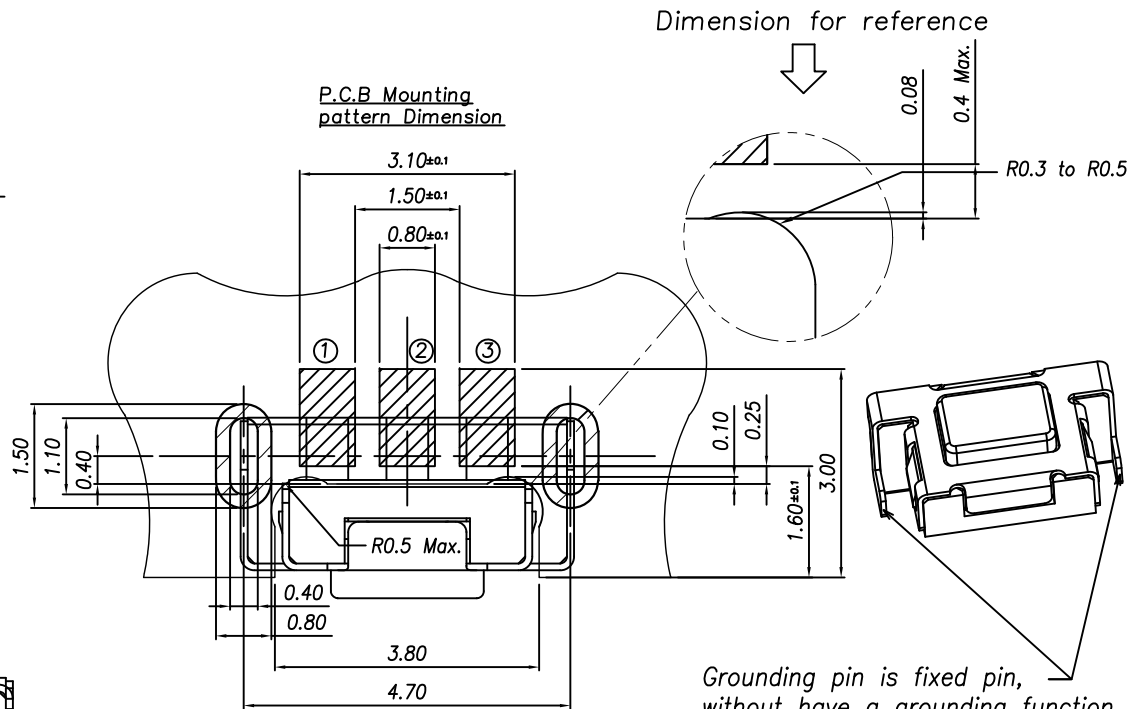

6	Cover	Stainless Steel	1	Ag Plate
5	Stem	Liquid Crystal Polymer	1	UL 94V-0 Natural)
4	Dust Cover	PI Film	1	
3	Contact	Stainless Steel	1	Ag Plate
2	Terminal	Brass	3	Ag Plate
1	Case	Liquid Crystal Polymer	1	UL 94V-0 (Black)
No.	Part Name	Material	Q'ty	Finishing

達立科技股份有限公司

Dawning Precision Co., Ltd.

TEL: 886-2-82271388 FAX: 886-2-82272198

DESIGN	Sean	SCALE		
DRAWING	Sean	UNIT	mm	
CHECK	Sean	SIZE	A4: 210*297	
APPROVAL	Eric	VERSION	01	

TOLERANCE UNLESS OTHERWISE STATED(mm)	PART NAME	TACT SWITCH
less than 10 — ±0.2	PART NO	TSS22-HG-350-T35
10~30 — ±0.3	DRAWING NO	
30~100 — ±0.5	DATE	2013/05/24
ANGLE — ±2°		