

△				
△				
△				
△				
ZONE	REV	DESCRIPTION	DATE	APPD.

RoHS
Compatible

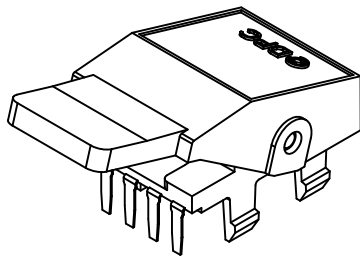

P.C.B Mounting pattern Dimension

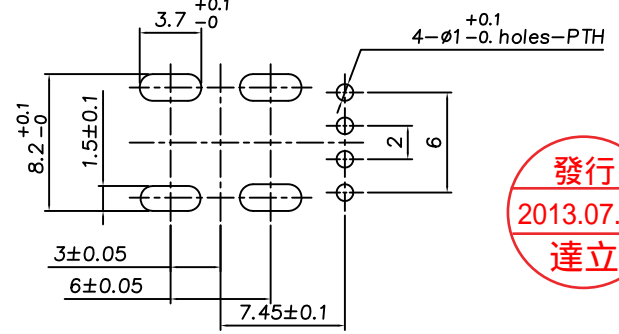

發行
2013.07.19
達立

Schematic

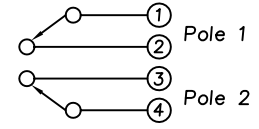

Time Lag Diagram

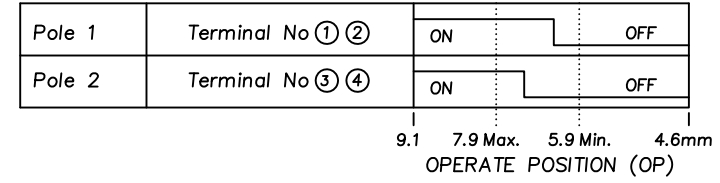

Notes :

- Functional characteristics :
 - Pretravel : 1.3mm Minimum
 - Off (Open) Starting position : 6.9±1.0 mm from PCB reference plane
- Free position : 9.1mm
- Limit position : 4.6mm

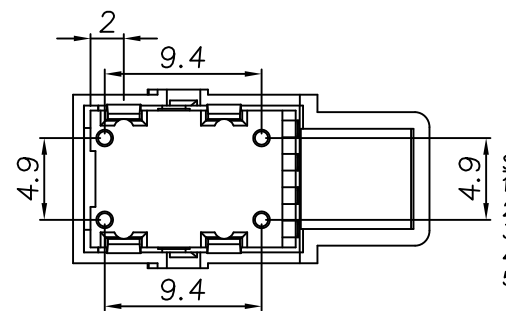
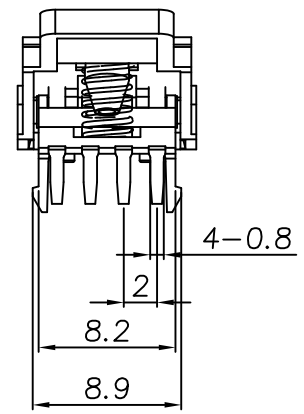
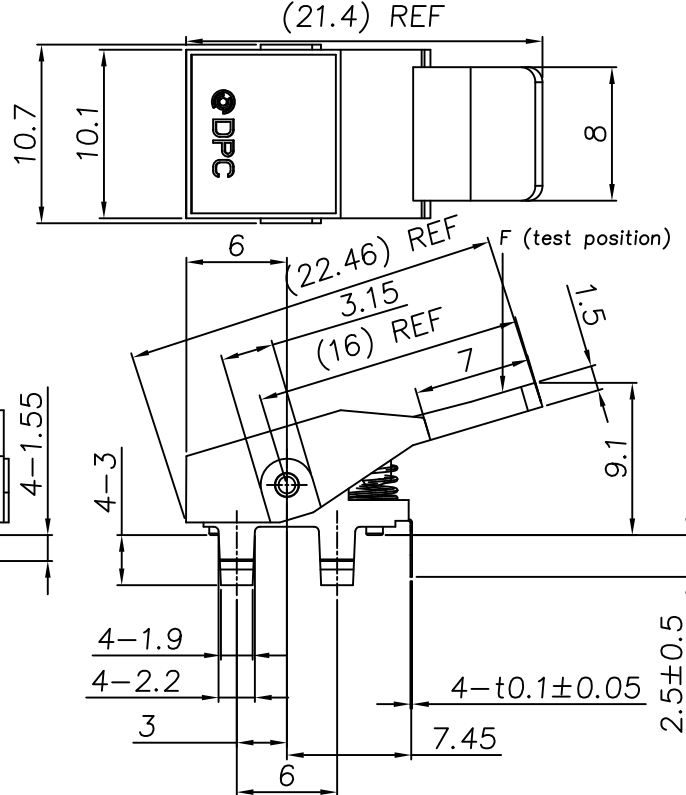

Specification

- Rating : DC53V 0.1A
- Contact resistance : 100mΩ Max.(initial)
- Insulation resistance : DC500V-100MΩ Min.
- Operation force : 30gf Max.(OPERATE POSITION)
- Life test : 300,000 cycles Min.

4	Spring	Piano Wire	1	Zn Plated
3	Terminal	Copper Alloy	4	Ag Plated
2	Lever	High Thermoplastic	1	UL94V-0 (Black)
1	Base	Nylon	1	UL94V-0 (Black)
NO	Part Name	Material	Q'ty	Finishing

達立科技股份有限公司
Dawning Precision Co.,Ltd.
TEL: 886-2-82271388 FAX: 886-2-82272198

DESIGN	Sean	SCALE		
DRAWING	Sean	UNIT	mm	
CHECK	Sean	SIZE	A4: 210*297	
APPROVAL	Eric	VERSION	02	

TOLERANCE UNLESS OTHERWISE STATED(mm)	PART NAME	HOOK SWITCH
less than 10 — ±0.3	PART NO	HS-D55-30-A
10~30 — ±0.3	DRAWING NO	
30~100 — ±0.5	DATE	2013/07/18
ANGIE — ±2°		

www.dawning2.com.tw