

**RoHS**  
**Compatible**

△				
△				
△				
△	02	修改上蓋扣合處	2009/08/05	Will.
ZONE	REV	DESCRIPTION	DATE	APPD.

Circuit diagram

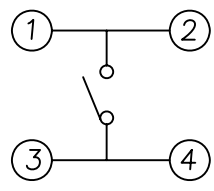

P.C.B Mounting pattern Dimension

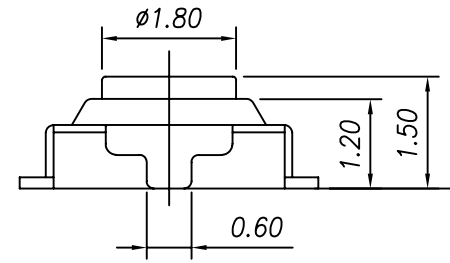
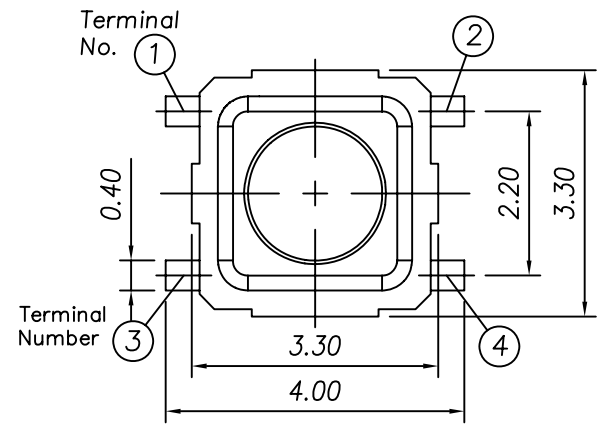
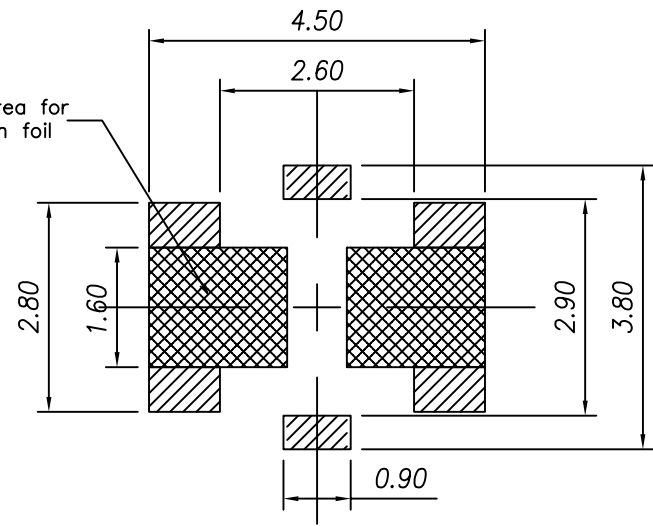

0.1C

Seating Plane

c

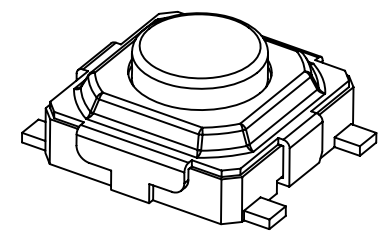
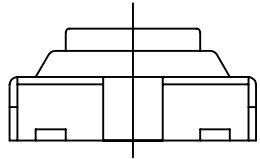

Order Information:  
TS-307KF--S066  
Force

Specification

- Rating : DC12V 50mA Max.
- Contact resistance : 100mΩ Max.
- Travel : 0.15±0.05mm
- 

Model	Operating Force	Life Cycles
TS-307KF-1	130±50gf	100,000 cycle
TS-307KF-2	160±50gf	100,000 cycle
TS-307KF-3	250±50gf	100,000 cycle

NO	Part Name	Material	Q'ty	Finishing
6	Dust Cover	Polyimide	1	Yellow
5	Terminal	Brass	4	Ag Plated
4	Cover	SUS	1	Ag Plated
3	Contact	SUS	2	Ag Clad
2	Stem	Liquid crystal polymer	1	Black
1	Case	Liquid crystal polymer	1	White

**達立科技股份有限公司**  
**Dawning Precision Co., Ltd.**  
TEL: 886-2-82271388 FAX: 886-2-82272198

DESIGN	Will	SCALE		
DRAWING	Will	UNIT	mm	
CHECK	Will	SIZE	A4: 210*297	
APPROVAL	Eric	VERSION	01	

TOLERANCE UNLESS OTHERWISE STATED(mm)	PART NAME	TACT SWITCH
less than 10 — ±0.2	PART NO	TS-307KF SERIES
10~30 — ±0.3	DRAWING NO	
30~100 — ±0.5	DATE	2012/10/05
ANGIE — ±2°		