

RoHS
Compatible

▲				
▲				
▲				
▲				
ZONE	REV	DESCRIPTION	DATE	APPD.

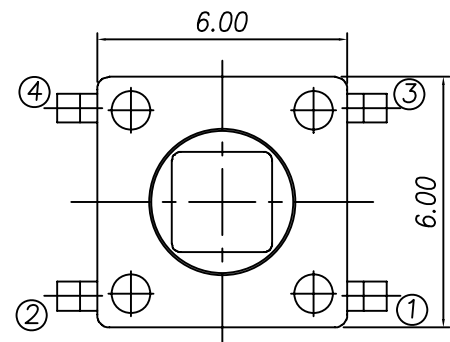

Circuit diagram

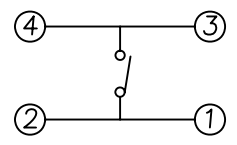

Knob size

Model#	L(mm)
TS-A02T	□ 2.4
TS-A02TA	□ 2.8

P.C.B Mounting pattern Dimension

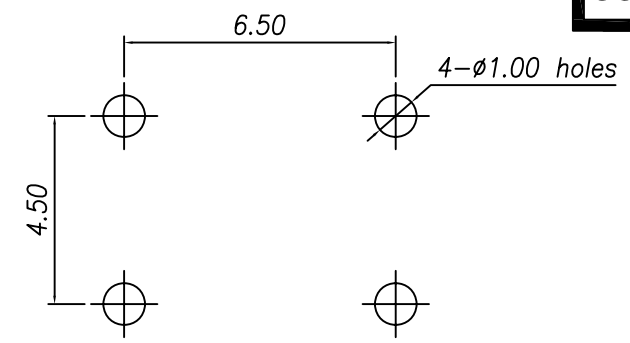

Order Information:
TS-A02T--S017

Force
Stem Size

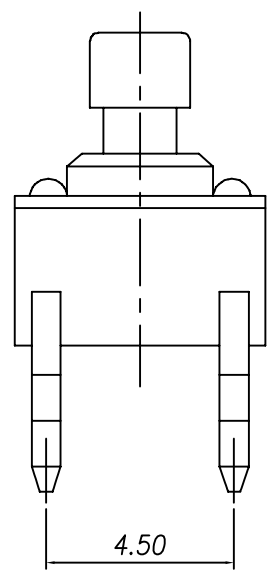
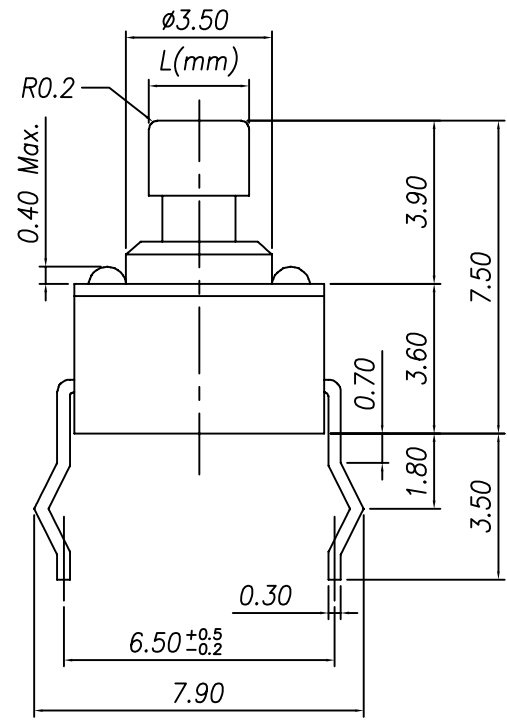

Specification

1. Rating : DC 12V 50mA Max.
2. Contact resistance : 100mΩ Max.
3. Insulation resistance : 100MΩ Min.
4. Travel : 0.25 +0.2/-0.1mm

5.	Model	Operating Force	Life Cycles	Stem Color
	TS-A02T-1	100±50gf	100,000 cycle	Brown
	TS-A02T-2	160±50gf	100,000 cycle	Blue
	TS-A02T-3	260±50gf	100,000 cycle	Red

5	Contact	Phosphor Bronze	1	Ag Plated
4	Cover	PET Film	1	-
3	Stem	PA66	1	-
2	Terminal	Brass	1	Ag Plated
1	Case	PA66	1	Black
NO	Part Name	Material	Q'ty	Finishing

達立科技股份有限公司
Dawning Precision Co., Ltd.
TEL: 886-2-82271388 FAX: 886-2-82272198

DESIGN	Will	SCALE		
DRAWING	Will	UNIT	mm	
CHECK	Will	SIZE	A4: 210*297	
APPROVAL	Eric	VERSION	01	

TOLERANCE UNLESS OTHERWISE STATED(mm)	PART NAME	TACT SWITCH
less than 10 ±0.3	PART NO	TS-A02T SERIES
10~30 ±0.4	DRAWING NO	
30~100 ±0.5	DATE	2010/11/17
ANGIE ±2°		