

RoHS
Compatible

△				
△				
△				
△				
ZONE	REV	DESCRIPTION	DATE	APPD.

P.C.B Mounting
pattern Dimension

Circuit diagram

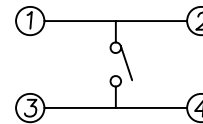

Order Information:
TS-A02S-_-S001
└── Force
└── Height

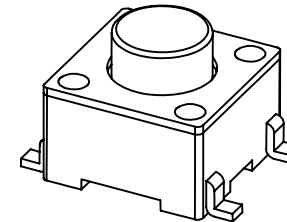

Knob height

Model	(H)mm	∅M
TS-A02S	4.3	3.5
TS-A02SA	5.0	3.5
TS-A02SB	7.0	3.4
TS-A02SC	8.0	3.4
TS-A02SD	9.5	3.4
TS-A02SE	7.3	3.4
TS-A02SF	12.5	3.0
TS-A02SG	13.5	3.0
TS-A02SH	17.0	3.0
TS-A02SJ	16.3	3.0
TS-A02SR	8.5	3.4
TS-A02SK	13.0	3.0

Specifications

1. Rating : DC 12V 50mA
2. Contact resistance : 100mΩ Max.
3. Travel : 0.25±0.1mm
- 4.

Model#	Operating force	Life Cycles
TS-A02S-2	160±50gf	100,000 Cycles
TS-A02S-3	250±50gf	100,000 Cycles

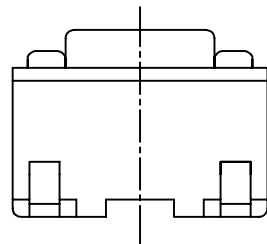
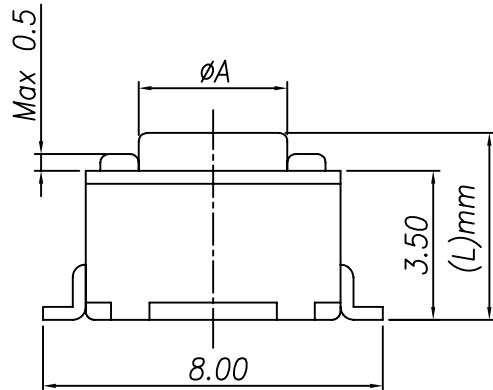
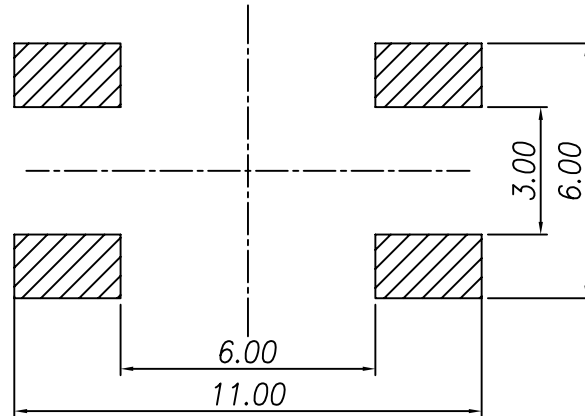
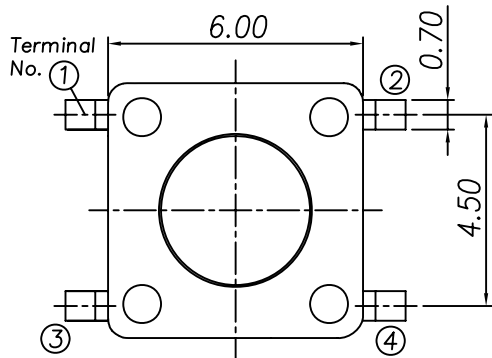

NO	Part Name	Material	Q'ty	Finishing
5	Case	PA6T	1	Black
4	Contact	Phosphor Bronze	1	Ag Clad 0.3μ
3	Stem	PA6T	1	Black
2	Terminal	Brass	4	Ni Plated 0.3μ, Ag Plated 0.5μ
1	Cover	Brass	1	Sn Plated 1~3μ

達立科技股份有限公司

Dawning Precision Co., Ltd.

TEL: 886-2-82271388 FAX: 886-2-82272198

DESIGN	Will	SCALE		
DRAWING	Will	UNIT	mm	
CHECK	Will	SIZE	A4: 210*297	
APPROVAL	Eric	VERSION	01	

TOLERANCE UNLESS OTHERWISE STATED(mm)	PART NAME	TACT SWITCH
less than 10 — ±0.3	PART NO	TS-A02S SERIES
10~30 — ±0.4	DRAWING NO	
30~100 — ±0.5	DATE	2012/06/18
ANGIE — ±2'		