

RoHS
Compatible

△				
△				
△				
△	02	修正為導圓角0.3	2009/04/15	WILL
ZONE	REV	DESCRIPTION	DATE	APPD.

P.C.B Mounting
pattern Dimension

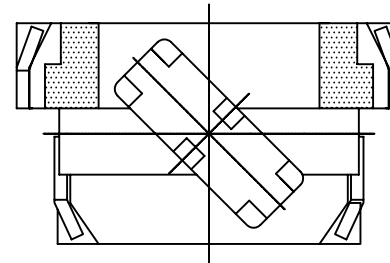
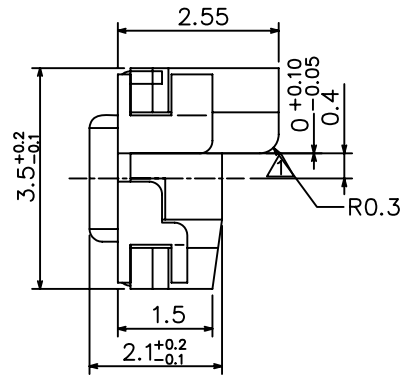
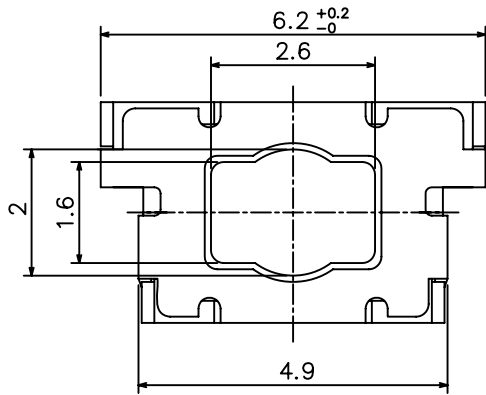
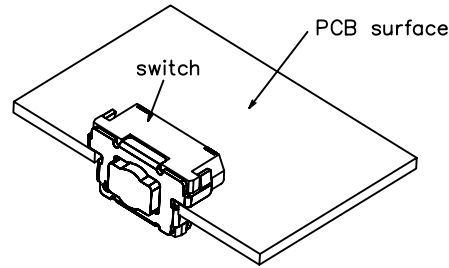
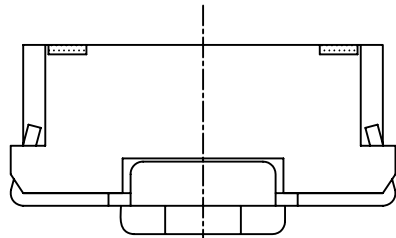
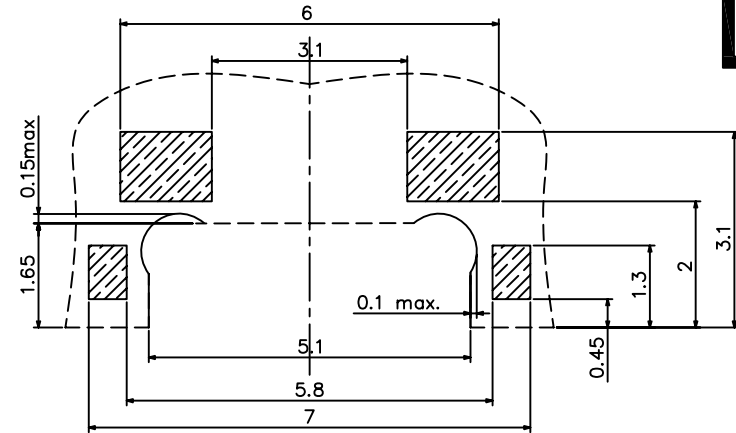

Specifications

1. Rating : 20mA 15V DC
2. Contact resistance : 100mΩ Max.
3. Travel ; 0.15±0.1mm
4. Operating force : 500gf±100gf
5. Operating life : 10,000 cycles

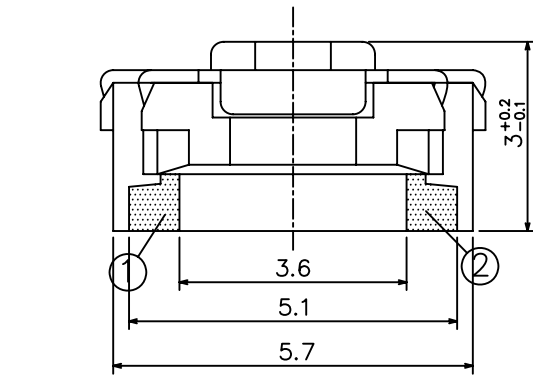

Circuit diagram

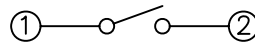

6	Cover	Stainless Steel	1	Ag Plate
5	Stem	Liquid Crystal Polymer	1	UL 94V-0 (Black)
4	Dust Cover	PI Film	1	
3	Contact	Stainless Steel	2	Ag Plate
2	Terminal	Phosphor Bronze	2	Ag Plate
1	Case	Liquid Crystal Polymer	1	UL 94V-0 (Black)
NO	PART NAME	MATERIAL	Q'TY	FINISHING

達立科技股份有限公司

Dawning Precision Co.,Ltd.

TEL: 886-2-82271388 FAX: 886-2-82272198

DESIGN	Will	SCALE		
DRAWING	Will	UNIT	mm	
CHECK	Will	SIZE	A4: 210*297	
APPROVAL	Eric	VERSION	02	

TOLERANCE UNLESS OTHERWISE STATED(mm)	PART NAME	TACT SWITCH
less than 10 — ±0.2	PART NO	TSS21-G-500-T20
10~30 — ±0.3	DRAWING NO	
30~100 — ±0.5	DATE	2009/12/22
ANGIE — ±2°		

www.dawning2.com.tw