

△				
△				
△				
△				
ZONE	REV	DESCRIPTION	DATE	APPD.

RoHS
Compatible

發行
2014.05.15
達立

CIRCUIT DIAGRAM

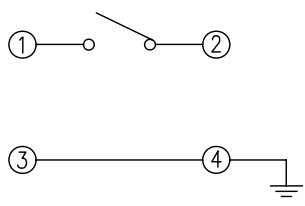

P.C.B MOUNTING
PATTERN DIMENSION

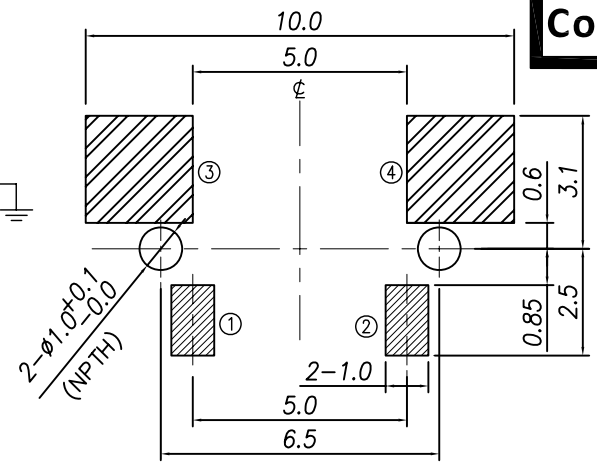

SPECIFICATION

1. Rating:DC 12V 50mA Max.
2. Contact resistance : 500mΩ Max.
3. Insulation resistance : 100MΩ Min(DC500V).
4. Withstand voltage : AC250V one minute.
5. Travel : 0.25±0.1mm.
6. Operating Force : 180±50g.
- 7.

Model No.	L(mm)	Force	Life
TSS33U-EG-180	3.2	180±50gf	50,000
TSS33UB-EG-180	3.9		
TSS33UC-EG-180	4.25		

NO.	PART NAME	Q'TY	MATERIAL	FINISHING
5	CONTACT PLATE	1	STAINLESS STEEL PLATE	Ag PLATING
4	TERMINAL	2	COPPER ALLOY	Ag PLATING OVER Ni PLATING
3	FRAME	1	LCP	BLACK
2	STEM	1	LCP	BLACK
1	COVER	1	CARBON STEEL PLATE	Matte Sn PLATING OVER Ni PLATING

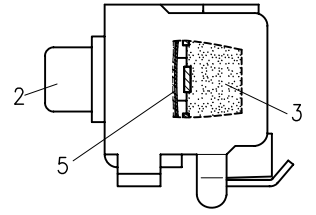
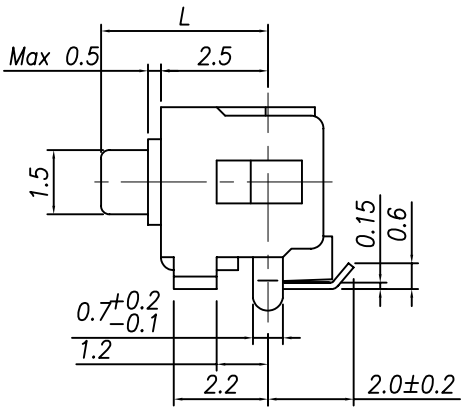
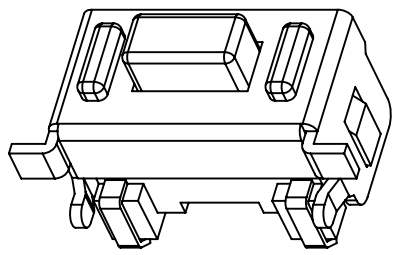
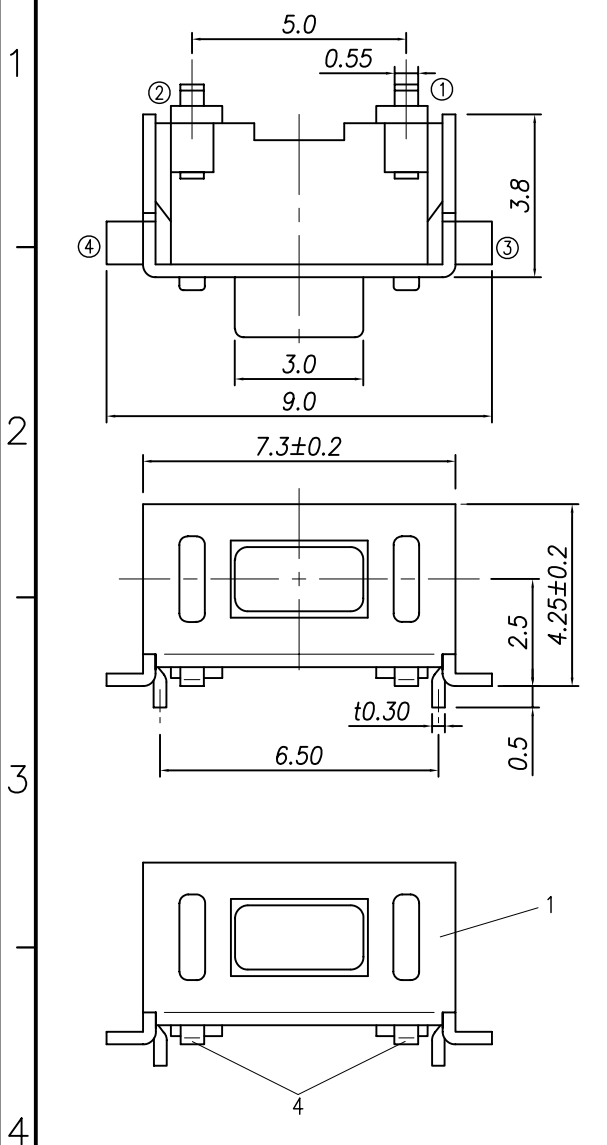

達立科技股份有限公司
Dawning Precision Co.,Ltd.
TEL: 886-2-82271388 FAX: 886-2-82272198

DESIGN	Sean	SCALE	
DRAWING	Sean	UNIT	mm
CHECK	Sean	SIZE	A4: 210*297
APPROVAL	Eric	VERSION	01

TOLERANCE UNLESS OTHERWISE STATED(mm)	PART NAME	TACT SWITCH
less than 10 — ±0.2	PART NO	TSS33Ux-EG-180-T10-S016 Series
10~30 — ±0.3	DRAWING NO	
30~100 — ±0.5	DATE	2014/05/15
ANGLE — ±2°		