

**RoHS**  
**Compatible**

發行  
2014.07.28  
達立

△				
△				
△				
△				
ZONE	REV	DESCRIPTION	DATE	APPD.

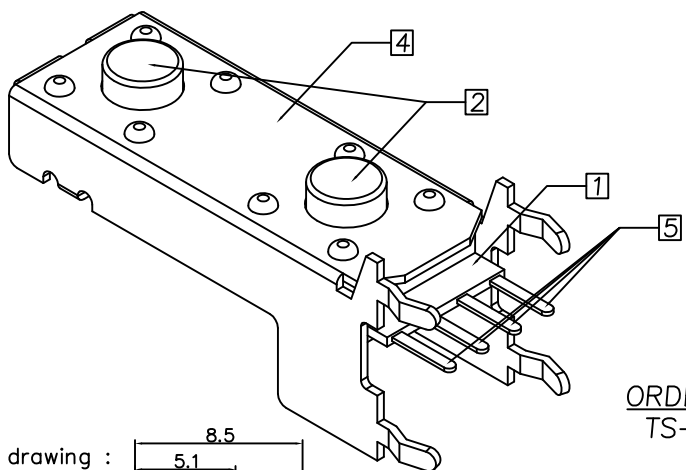
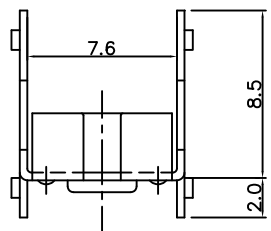

P.C.B MOUNTING  
PATTERN DIMENSION

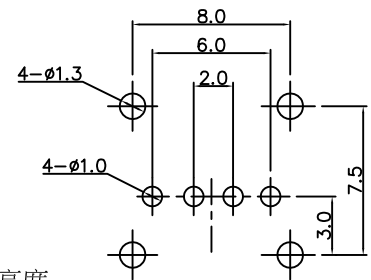

ORDER INFORMATION:

TS-A02MVxx-x  
Force  
1 Stem Height  
2 Stem Height  
(Both height the same as blank)  
EX: TS-A02MVAD(H3.85&H8.35)組裝成品高度  
TS-A02MVBF(H5.85&H11.35)組裝成品高度

CIRCUIT DIAGRAM

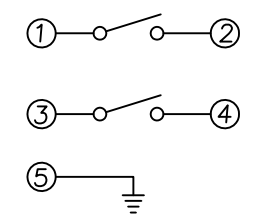

SPECIFICATION

- Rating : DC 12V. 50mA Max.
- Travel : 0.25±0.1mm
- Contact resistance : 100mΩ Max.
- Insulation resistance : 100MΩ Min.
- Operating force : 160±50gf ; 250±50gf.
- Operating life : 160g-80,000 cycles Min ; 250g-50,000 cycles Min.

5	Terminal	Brass C2680 t0.3	4	Ag Plated 0.25μm Min over Ni plated 0.2 μm Min.
4	Bracket	SPTe t0.4	1	Sn Plated 2.5μm Min over Ni plated 0.2 μm Min.
3	Contact	PBS C5210 t0.05	2	Ag Clad 0.15μm Min.
2	Stem	PPA 30%GF	2	Black(Natural)
1	Base	PPA 30%GF	1	Black(Natural)
NO	Part Name	Material	Q'ty	Finishing

Pls ref attached drawing :  
DTS-A02MV-KN series

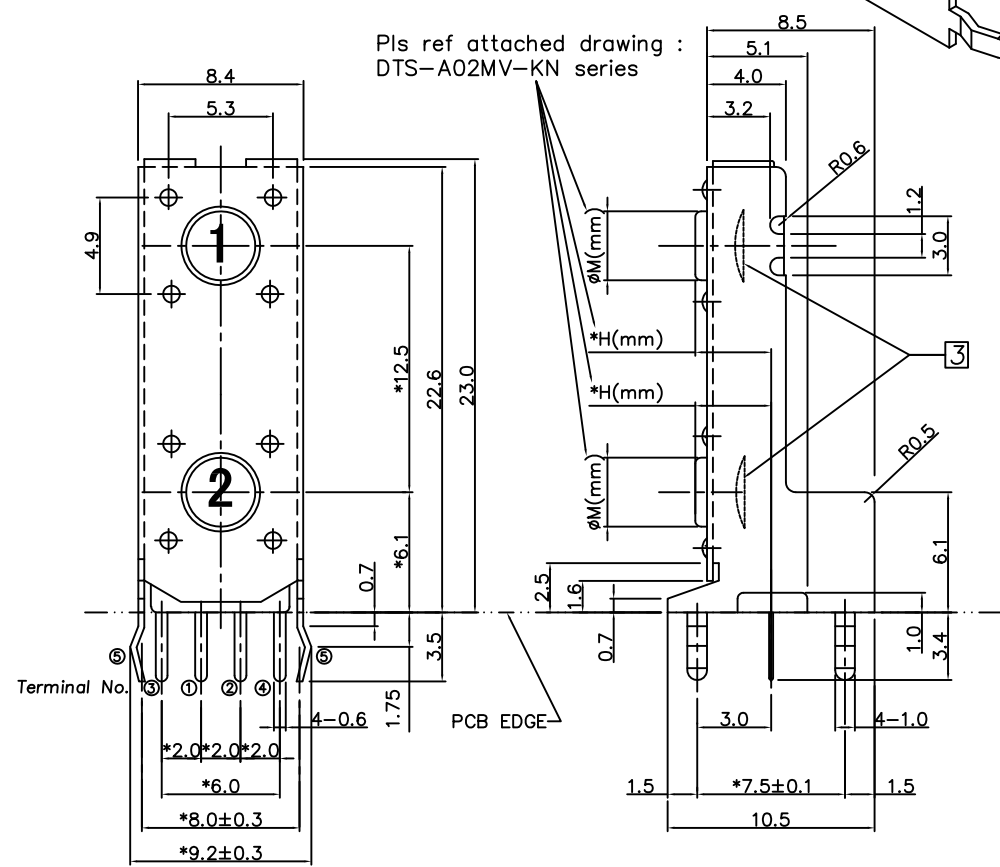

**達立科技股份有限公司**  
**Dawning Precision Co.,Ltd.**  
TEL: 886-2-82271388 FAX: 886-2-82272198

DESIGN	Frank	SCALE	
DRAWING	Frank	UNIT	mm
CHECK	Frank	SIZE	A4: 210*297
APPROVAL	Eric	VERSION	X0

TOLERANCE UNLESS OTHERWISE STATED(mm)	PART NAME	TACT SWITCH
less than 10 ±0.1	PART NO	TS-A02MVxx-x series
10~30 ±0.2	DRAWING NO	ASSEMBLY
30~100 ±0.3	DATE	2014/07/17
ANGLE ±2°		

**RoHS**  
Compatible

發行  
2014.07.30  
達立

△				
△				
△				
△	02	Update drawing	073014	Frank
ZONE	REV	DESCRIPTION	DATE	APPD.

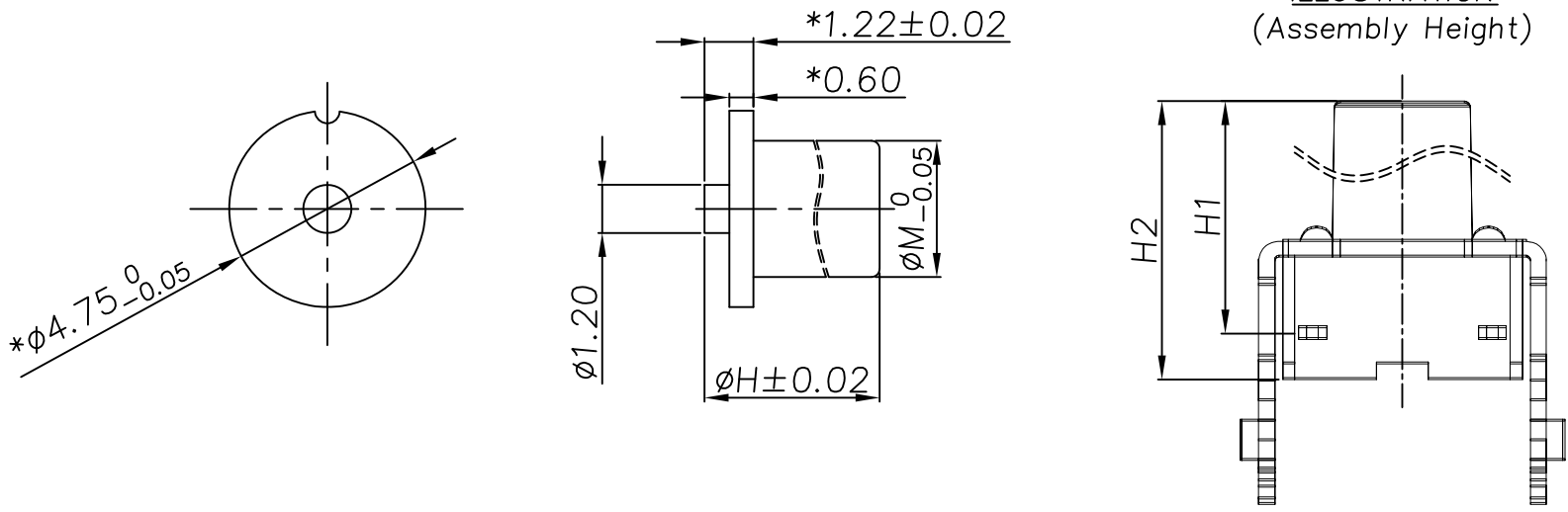

- Notes :
1. Material :  
Case : PPA,Black.
  2. Flash not to exceed 0.05 mm.  
Unless pin hole flash not to exceed 0.03 mm.
  3. Parting line mismatch not to exceed 0.05 mm.
  4. Gate to be flash 0.1 mm Max.
  5. "\*" Mark is inspection dimension.

Model	H1(mm)	H2(mm)	M(mm)	H(mm)
A	3.85	5.0	3.4	3.0
B	5.85	7.0	3.3	5.0
D	8.35	9.5	3.3	7.5
F	11.35	12.5	3.0	10.5

**達立科技股份有限公司**  
**Dawning Precision Co., Ltd.**  
TEL: 886-2-82271388 FAX: 886-2-82272198

DESIGN	Frank	SCALE		
DRAWING	Frank	UNIT	mm	
CHECK	Frank	SIZE	A4: 210*297	
APPROVAL	Eric	VERSION	X1	

TOLERANCE UNLESS OTHERWISE STATED(mm)	PART NAME	TACT SWITCH
0 — ±0.20	PART NO	DTS-A02MV-KN series
0.0 — ±0.10	DRAWING NO	KNOB
0.00 — ±0.05	DATE	2014/07/30
0.000 — ±0.03		

www.dawning2.com.tw