

RoHS
Compatible

達立
2015.03.02
發行

△				
△				
△				
△				
ZONE	REV	DESCRIPTION	DATE	APPD.

*Order Information:
TS-A03x-x-S001
Force
Height

Model	H	φA
TS-A03	4.3	6.8
TS-A03BH	7.5	6.7
TS-A03CH	5.0	6.8
TS-A03FH	8.5	6.6
TS-A03G	5.5	6.8
TS-A03H	6.0	6.7
TS-A03I	6.5	6.7
TS-A03J	7.0	6.7
TS-A03L	8.0	6.6
TS-A03M	9.0	6.6
TS-A03F	9.5	6.6

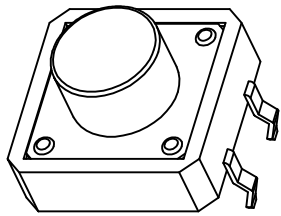
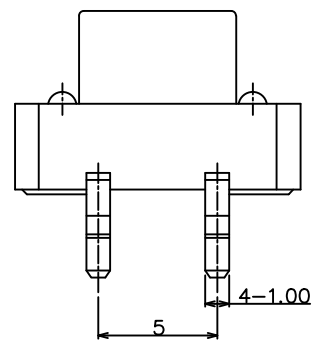
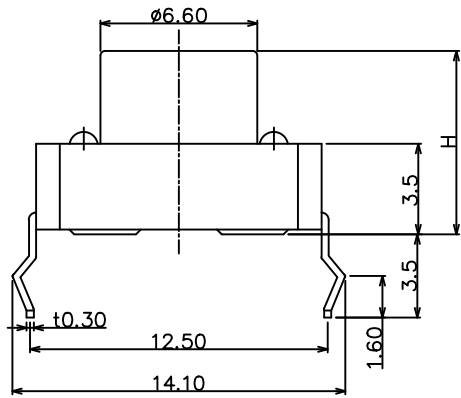
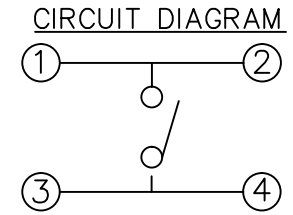
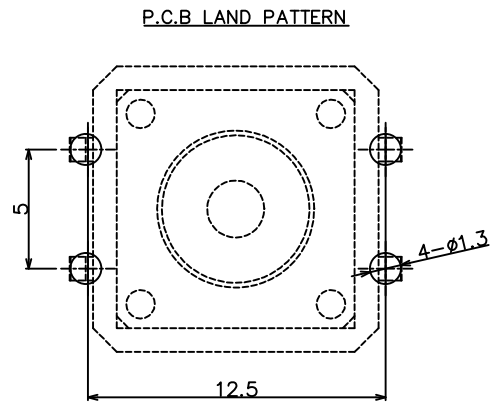
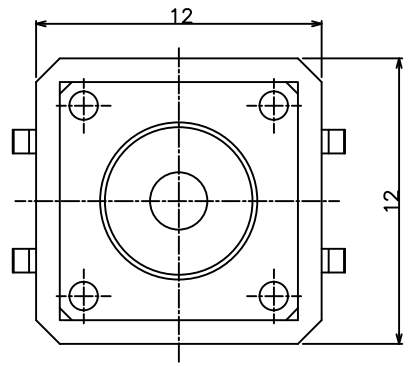

Specifications

1. Rating : DC 12V, 50mA Max.
2. Insulation Resistance : 100MΩ Min.
3. Travel: 0.25±0.1mm
4. Contact resistance: 100mΩ Max.
5. Operating life: 100,000 cycles Min.

	Operating force
TS-A03-2	160±30 gf
TS-A03-3	250±50 gf

No.	Part Name	Material	Q'ty	Finishing
5	Stem	PolyAmide	1	(Black)
4	Cover	Steel	1	
3	Contact	Copper alloy	1	Ag Clad
2	Terminal	Brass	4	
1	Case	PolyAmide	1	(Black)

達立科技股份有限公司
Dawning Precision Co., Ltd.
TEL: 886-2-82271388 FAX: 886-2-82272198

DESIGN	Ross	SCALE		
DRAWING	Ross	UNIT	mm	
CHECK	Elsa	SIZE	A4: 210*297	
APPROVAL	Eric	VERSION	01	

TOLERANCE UNLESS OTHERWISE STATED(mm)	PART NAME	TACT SWITCH
less than 10 — ±0.2	PART NO	TS-A03x-x-S001 SERIES
10~30 — ±0.3	DRAWING NO	
30~100 — ±0.5	DATE	2013/09/26
ANGLE — ±2'		