

RoHS
Compatible

△				
△				
△				
△				
ZONE	REV	DESCRIPTION	DATE	APPD.

Circuit diagram

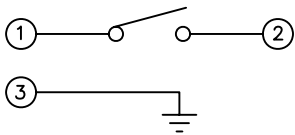

P.C.B Mounting pattern Dimension

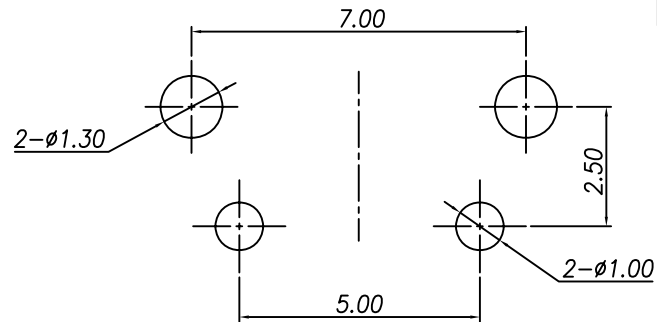

Order Information:
TS-A01V--S033
Force Height

Model#	L(mm)
TS-A01V	3.15
TS-A01VA	3.85

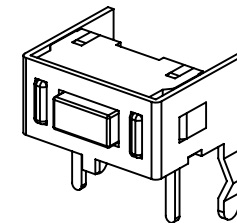

Specifications

1. Rating : 50mA 12V DC
2. Contact resistance : 100mΩ max.
3. Insulation resistance : 100MΩ min, 100V DC
4. Withstanding voltage : 250V AC- 1minute
5. Travel : 0.25±0.1mm
- 6.

Model	Operating Force	Life Cycles
TS-A01V-1	130±50gf	50,000 cycle
TS-A01V-2	180±50gf	50,000 cycle
TS-A01V-3	250±50gf	30,000 cycle

NO	Part Name	Material	Q'ty	Finishing
5	Contact Plate	Stainless Steel	1	Ag Clad
4	Stem	Nylon66	1	Black
3	Bracket	SPTe	1	Sn Plated
2	Terminal	Brass	2	Ag Plated
1	Case	Nylon 66	1	Black

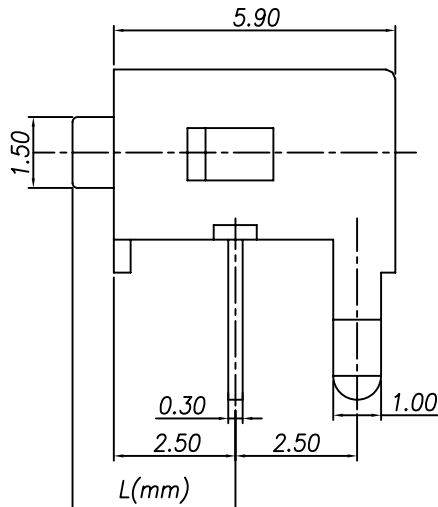
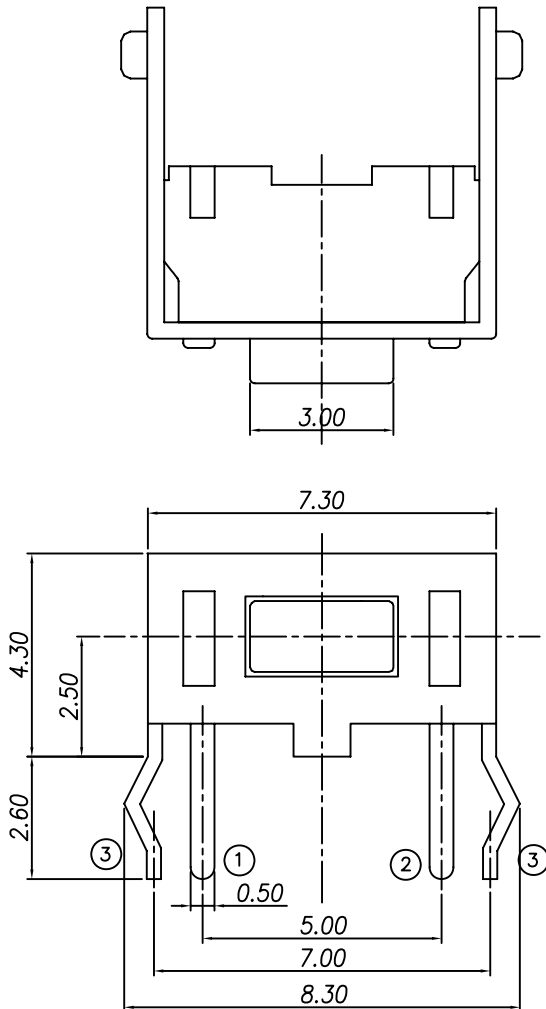

達立科技股份有限公司
Dawning Precision Co., Ltd.
TEL: 886-2-82271388 FAX: 886-2-82272198

DESIGN	Will	SCALE		
DRAWING	Will	UNIT	mm	
CHECK	Will	SIZE	A4: 210*297	
APPROVAL	Eric	VERSION	01	

TOLERANCE UNLESS OTHERWISE STATED(mm)	PART NAME	TACT SWITCH
less than 10 ±0.2	PART NO	TS-A01V SERIES
10~30 ±0.3	DRAWING NO	
30~100 ±0.5	DATE	2009/12/10
ANGIE ±2°		