

**RoHS**  
Compatible

▲				
▲				
▲				
▲				
ZONE	REV	DESCRIPTION	DATE	APPD.

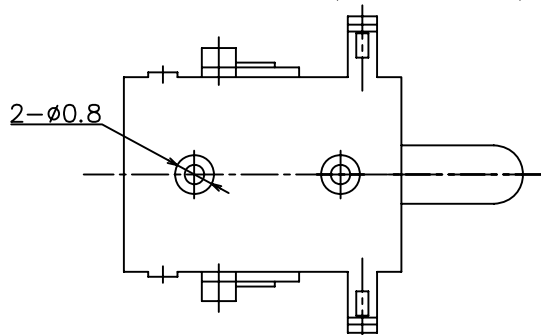

Circuit Diagram

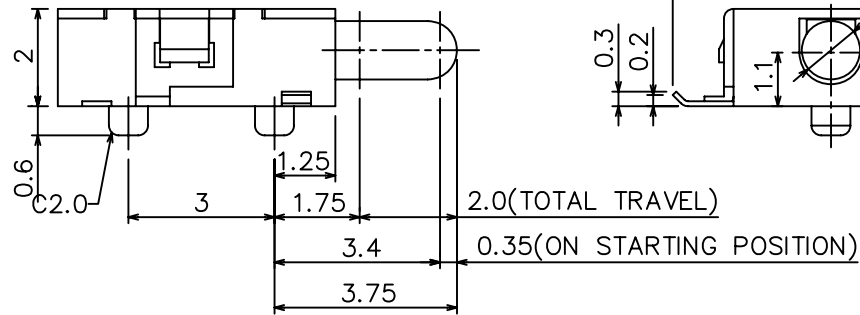
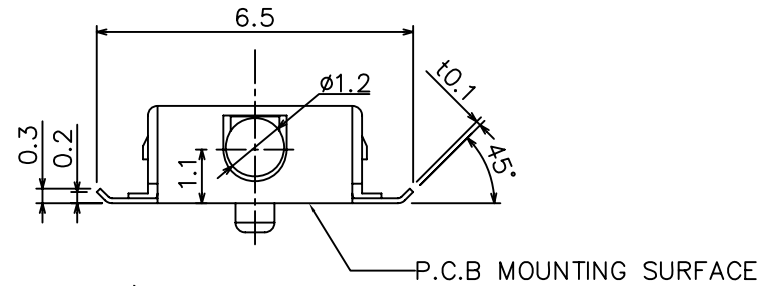
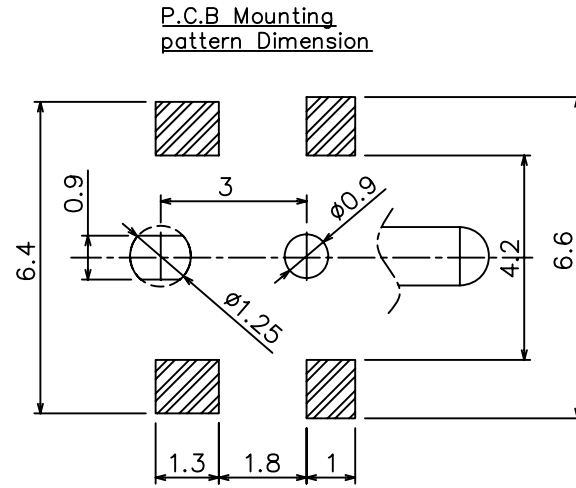
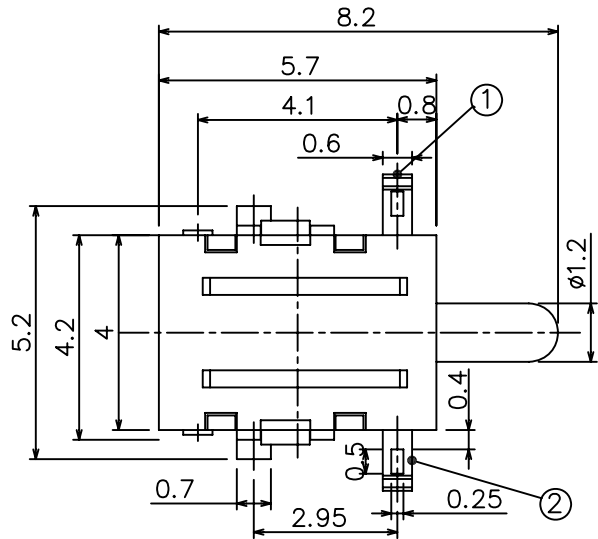
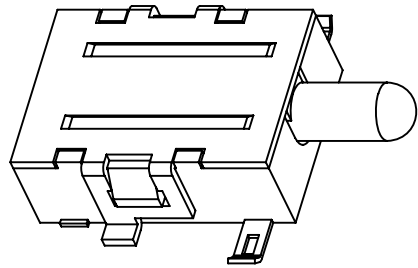
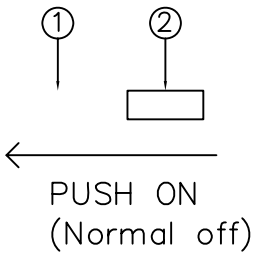

Specifications

1. Rating : DC 12v,100mA(resistive load)
2. Operating force : 50gf max
3. Life cycle : 50,000 cycles
4. Color : case,actuator-black

**達立科技股份有限公司**

**Dawning Precision Co.,Ltd.**

TEL: 886-2-82271388 FAX: 886-2-82272198

DESIGN	Will	SCALE		
DRAWING	Will	UNIT	mm	
CHECK	Will	SIZE	A4: 210*297	
APPROVAL	Eric	VERSION	01	

TOLERANCE UNLESS OTHERWISE STATED(mm)
less than 10 — ±0.2
10~30 — ±0.3
30~100 — ±0.5
ANGIE — ±2°

PART NAME	DETECTOR SWITCH
PART NO	DS-B50
DRAWING NO	
DATE	2009/09/04