

RoHS
Compatible

Specifications

1. Rating : 50mA 12V DC
2. Contact resistance : 100mΩ Max.
3. Insulation resistance : 100MΩ min,100V DC
4. Withstanding voltage : 250V AC – 1minute
5. Travel : 0.25^{+0.2}_{-0.1} mm
- 6.

▲				
▲				
▲				
▲				
ZONE	REV	DESCRIPTION	DATE	APPD.

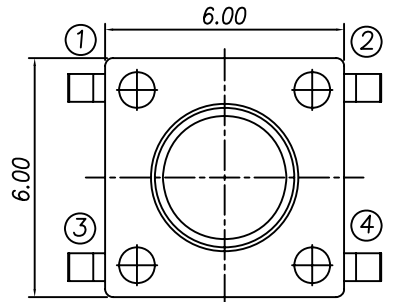

Order Information:
TS-A02--S017
Force Height

Model	L	M	Stem Color	O/Force
TS-A02-1	4.3	3.5	Brown	100±50gf
TS-A02A-1	5.0	3.5		
TS-A02B-1	7.0	3.34		
TS-A02C-1	8.0	3.2		
TS-A02D-1	9.5	3.1		
TS-A02E-1	7.3	3.24		
TS-A02H-1	17.0	2.8		
TS-A02R-1	8.5	3.09		
TS-A02K-1	13.0	2.87		

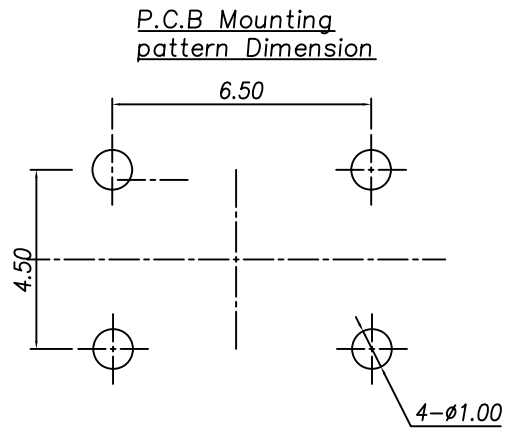

Model	L	M	Stem Color	O/Force
TS-A02-2	4.3	3.5	White	160±50gf
TS-A02A-2	5.0	3.5	Black	
TS-A02B-2	7.0	3.34	Black	
TS-A02C-2	8.0	3.2	White	
TS-A02D-2	9.5	3.1	Black	
TS-A02E-2	7.3	3.24	Ivory	
TS-A02H-2	17.0	2.8	Black	
TS-A02R-2	8.5	3.09	Black	
TS-A02K-2	13.0	2.87	Black	

Circuit diagram

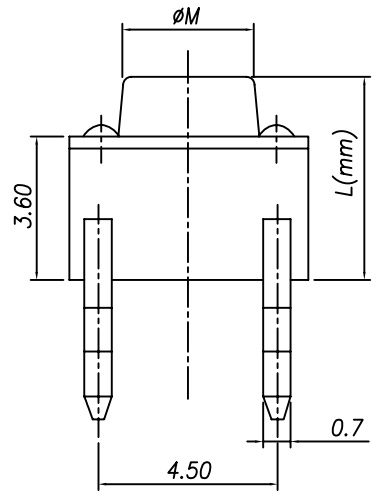
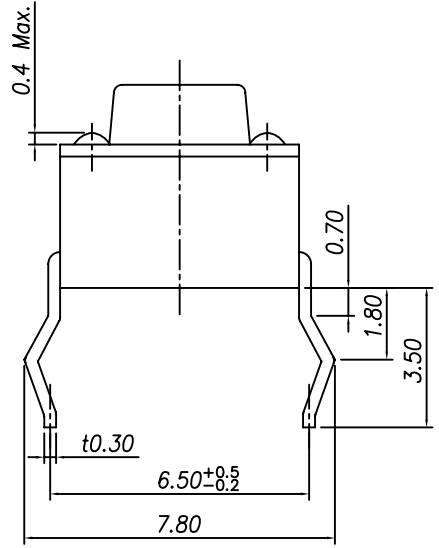
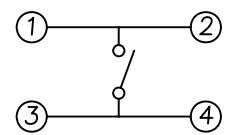

Model	L	M	Stem Color	O/Force
TS-A02-3	4.3	3.5	Red	250±50gf
TS-A02A-3	5.0	3.5		
TS-A02B-3	7.0	3.34		
TS-A02C-3	8.0	3.2		
TS-A02D-3	9.5	3.1		
TS-A02E-3	7.3	3.24		
TS-A02H-3	17.0	2.8		
TS-A02R-3	8.5	3.09		
TS-A02K-3	13.0	2.87		

5	Contact	Phosphor Bronze	1	Ag Plated
4	Stem	Nylon66	1	-
3	Cover	PET	1	White
2	Terminal	Brass	4	Ag Plated
1	Case	Nylon 66	1	Black
NO	Part Name	Material	Q'ty	Finishing

達立科技股份有限公司
Dawning Precision Co., Ltd.
TEL: 886-2-82271388 FAX: 886-2-82272198

DESIGN	Will	SCALE		
DRAWING	Will	UNIT	mm	
CHECK	Will	SIZE	A4: 210*297	
APPROVAL	Eric	VERSION	01	

TOLERANCE UNLESS OTHERWISE STATED(mm)	PART NAME	TACT SWITCH
less than 10 — ±0.3	PART NO	TS-A02 SERIES
10~30 — ±0.4	DRAWING NO	
30~100 — ±0.5	DATE	2009/12/10
ANGIE — ±2°		