

RoHS
Compatible

▲				
▲				
▲				
▲				
ZONE	REV	DESCRIPTION	DATE	APPD.

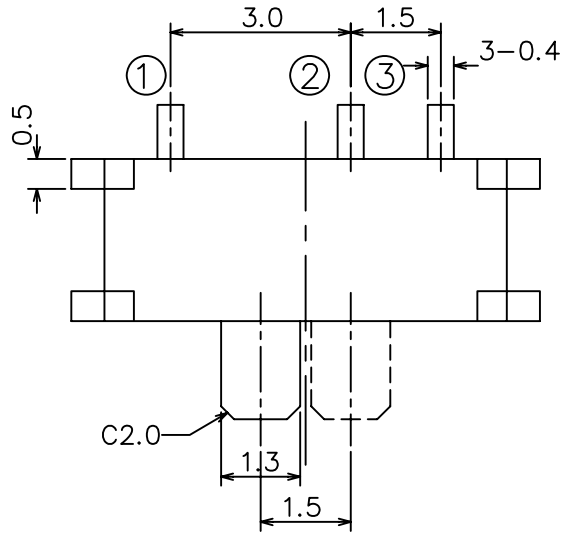

Circuit Diagram

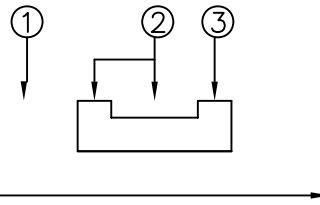

P.C.B Mounting pattern Dimension

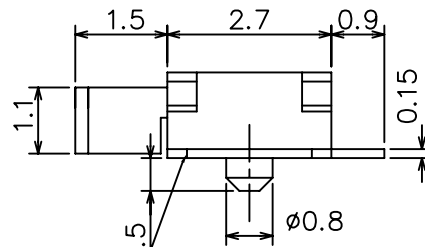
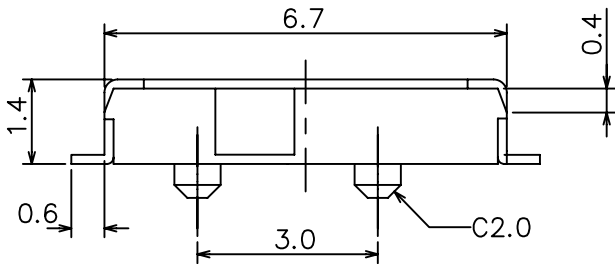
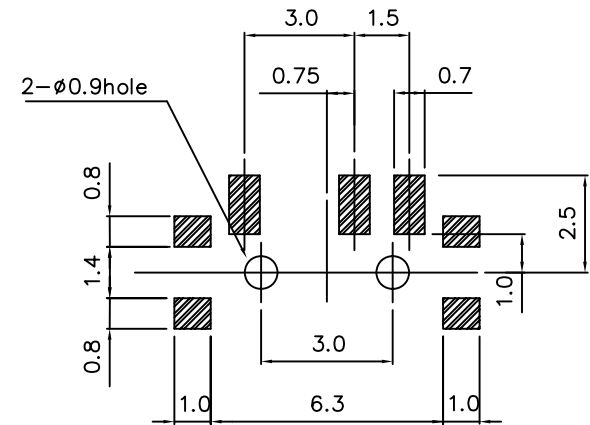

P.C BOARD MOUNTING FACE

Specifications

1. Rating : 4V DC, 0.3A
2. Contact resistance : 70mΩ max.
3. Insulation resistance : 100MΩ min.
4. Operating force : 150±100gf
5. Operating life : 10,000 cycles

達立科技股份有限公司

Dawning Precision Co., Ltd.

TEL: 886-2-82271388 FAX: 886-2-82272198

DESIGN	Will	SCALE			TOLERANCE UNLESS OTHERWISE STATED(mm)	PART NAME	SLIDE SWITCH
DRAWING	Will	UNIT	mm		less than 10 — ±0.2	PART NO	SS-B90AP-W-SP-S100
CHECK	Will	SIZE	A4: 210*297		10~30 — ±0.3	DRAWING NO	
APPROVAL	Eric	VERSION	01		30~100 — ±0.5	DATE	2009/12/09
					ANGIE — ±2°		

						PART NAME	SLIDE SWITCH
						PART NO	SS-B90AP-W-SP-S100
						DRAWING NO	
						DATE	2009/12/09