

**RoHS
Compatible**

△				
△				
△				
△				
ZONE	REV	DESCRIPTION	DATE	APPD.

Circuit diagram

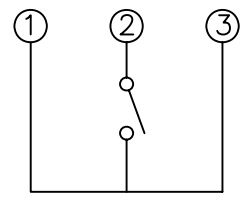

Specification

1. Rating : DC 12V 50mA Max.
2. Contact resistance : 100mΩ Max.
3. Insulation resistance : 100MΩ Min.
4. Travel : 0.15±0.1mm
5. Operating life : 200,000 cycles Min.
6. Operating force: 160±50g

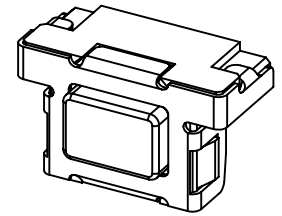
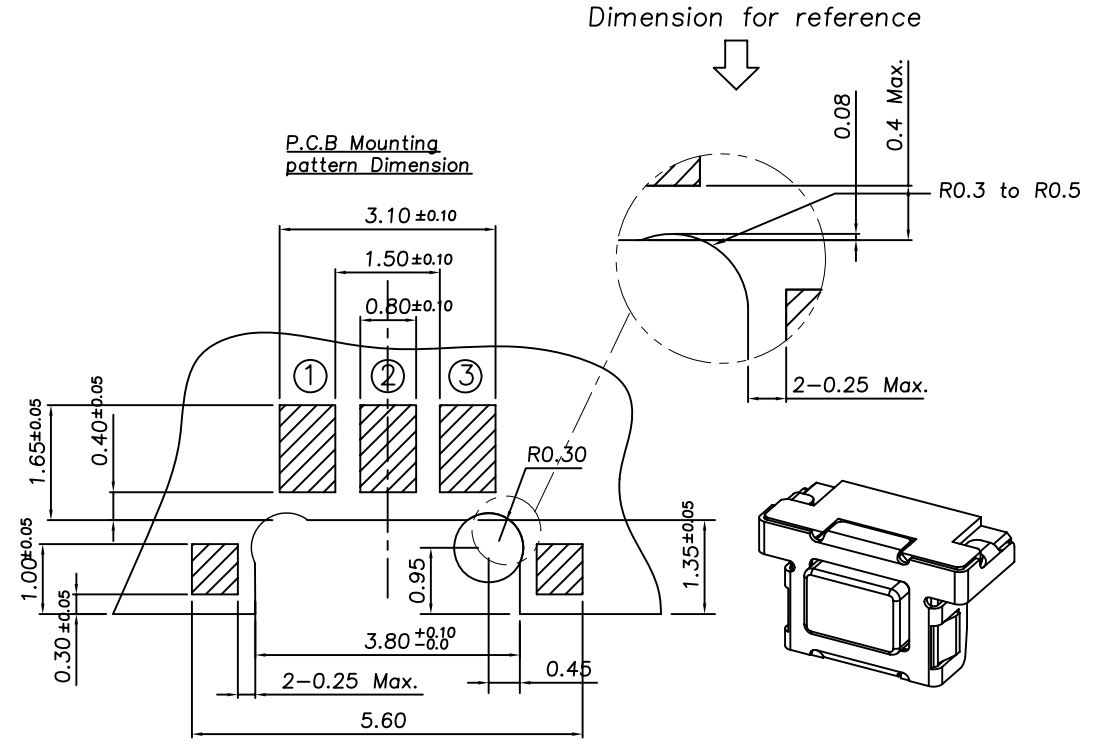
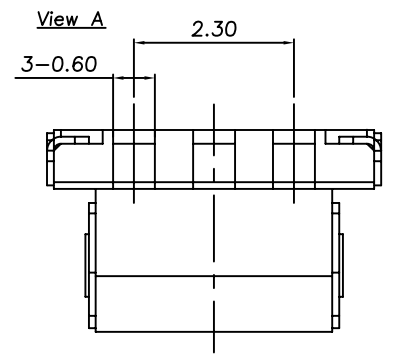
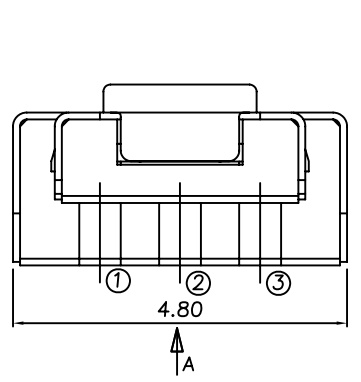
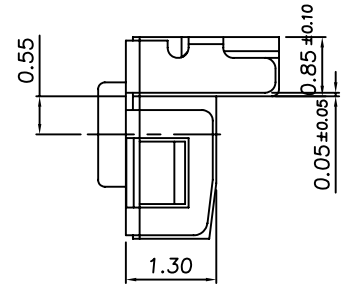
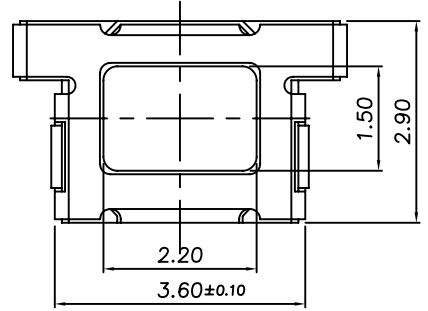
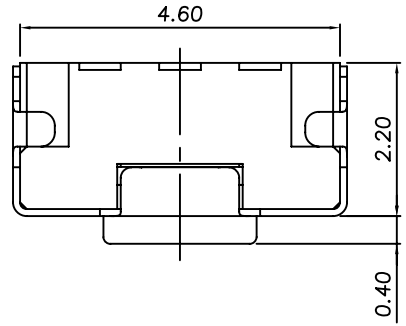

6	Cover	Stainless Steel	1	Ag Plate
5	Stem	Liquid Crystal Polymer	1	UL 94V-0 (Black)
4	Dust Cover	PI Film	1	
3	Contact	Stainless Steel	2	Ag Plate
2	Terminal	Brass	3	Ag Plate
1	Case	Liquid Crystal Polymer	1	UL 94V-0 (Black)
No.	Part Name	Material	Q'ty	Finishing

達立科技股份有限公司
Dawning Precision Co., Ltd.
TEL: 886-2-82271388 FAX: 886-2-82272198

DESIGN	Will	SCALE		
DRAWING	Will	UNIT	mm	
CHECK	Will	SIZE	A4: 210*297	
APPROVAL	Eric	VERSION	01	

TOLERANCE UNLESS OTHERWISE STATED(mm)	PART NAME	TACT SWITCH
less than 10 — ±0.2	PART NO	TSS22-G2-160-T35
10~30 — ±0.3	DRAWING NO	
30~100 — ±0.5	DATE	2012/11/19
ANGLE — ±2°		