

RoHS
Compatible

△				
△				
△				
△				
ZONE	REV	DESCRIPTION	DATE	APPD.

Circuit Diagram

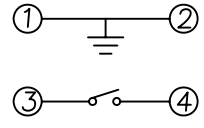

P.C.B Mounting
Pattern Dimension

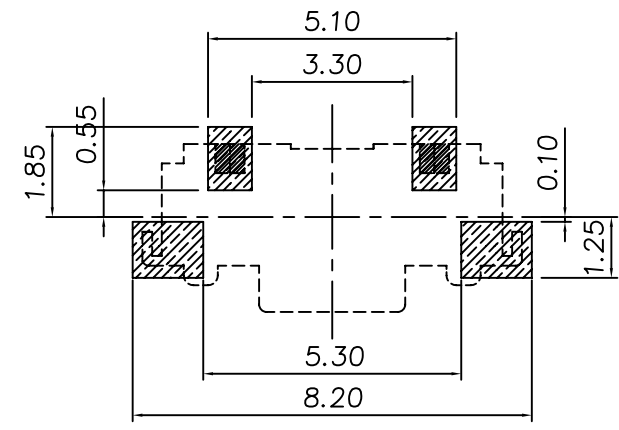

Order Information:
TS-A12--S055

Force

Specification

1. Rating : DC 12V 50mA Max.
2. Travel : 0.25±0.1mm.
3. Contact resistance : 100mΩ Max.
- 4.

Model#	Operating Force	Life Cycles
TS-A12-1	130±50gf	50,000 Cycles
TS-A12-2	160±50gf	50,000 Cycles
TS-A12-3	250±50gf	50,000 Cycles

Terminal
NO.

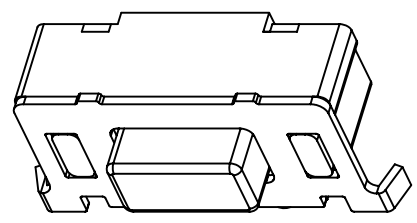
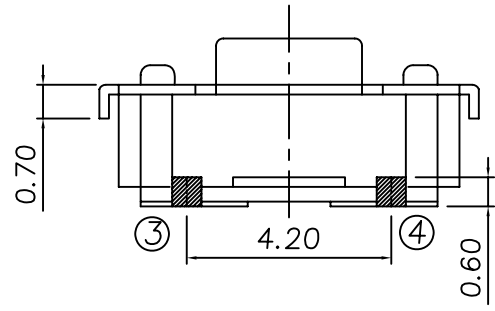
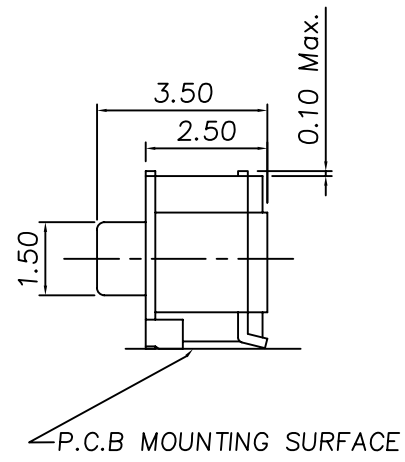
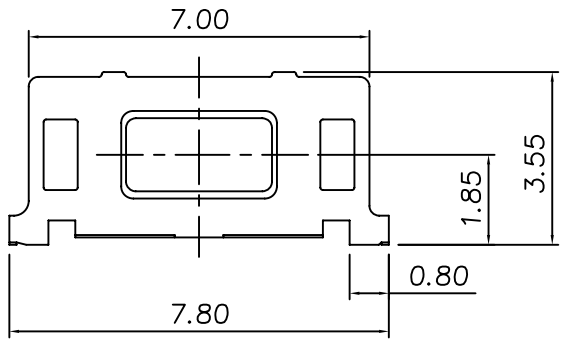
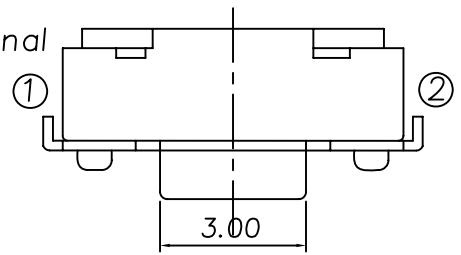

5	Contact	Stainless	1	Ag Clad
4	Cover	SPTE	1	Sn Plated
3	Knob	Polyamide	1	Black
2	Case	Polyamide	1	White
1	Terminal	Brass	2	Ag Plated
NO	Part Name	Material	Q"ty	Finishing

達立科技股份有限公司
Dawning Precision Co., Ltd.
TEL: 886-2-82271388 FAX: 886-2-82272198

DESIGN	Will	SCALE	
DRAWING	Will	UNIT	mm
CHECK	Will	SIZE	A4: 210*297
APPROVAL	Eric	VERSION	01

TOLERANCE UNLESS OTHERWISE STATED(mm)	PART NAME	TACT SWITCH
less than 10 — ±0.2	PART NO	TS-A12-2-S055
10~30 — ±0.3	DRAWING NO	
30~100 — ±0.5	DATE	2012/07/10
ANGIE — ±2'		